

## Sectional Drawing of SCP pumps

### Pump case

The pump case is of rigid design with a generous wall thickness, giving good protection against erosion and corrosion.

### Shaft sealing

Shaft sealing can be with:  
- soft packing  
- mechanical seal.

### Shaft bearing bracket

The heavy duty console with incorporated lantern assures silent operation.

### Impeller

Fully enclosed, single -piece casting gives reliability, long trouble-free operation and high efficiency.

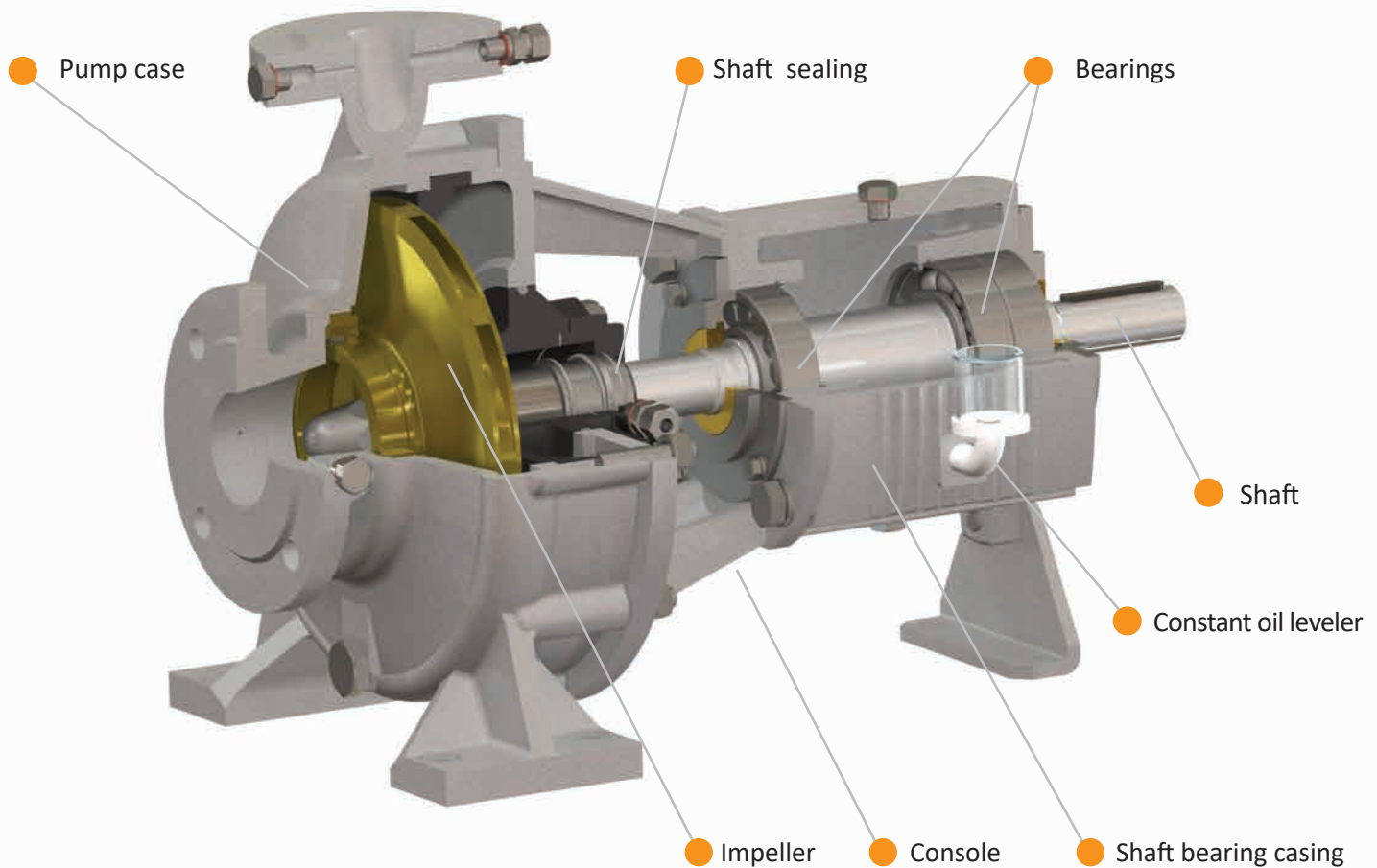

### Bearings

The shaft is protected by a replaceable shaft sleeve in stainless steel.

### Shafts

Ample dimensioned single and double row ball bearings improve the stiffness and minimize shaft deflection.

### Console

Aligned between the bearing bracket and the pump case.

### Constant oil leveler

For maintaining a constant oil level for efficient lubrication of the bearings.

### Technical data:

Capacity: up to 2500 m<sup>3</sup>/h  
Head: up to 150 m  
Pump size: up to DN300  
Temperature: up to 160°C